

		REVISIONS			
ZONE	REV.	DESCRIPTION		DATE	APPROVED

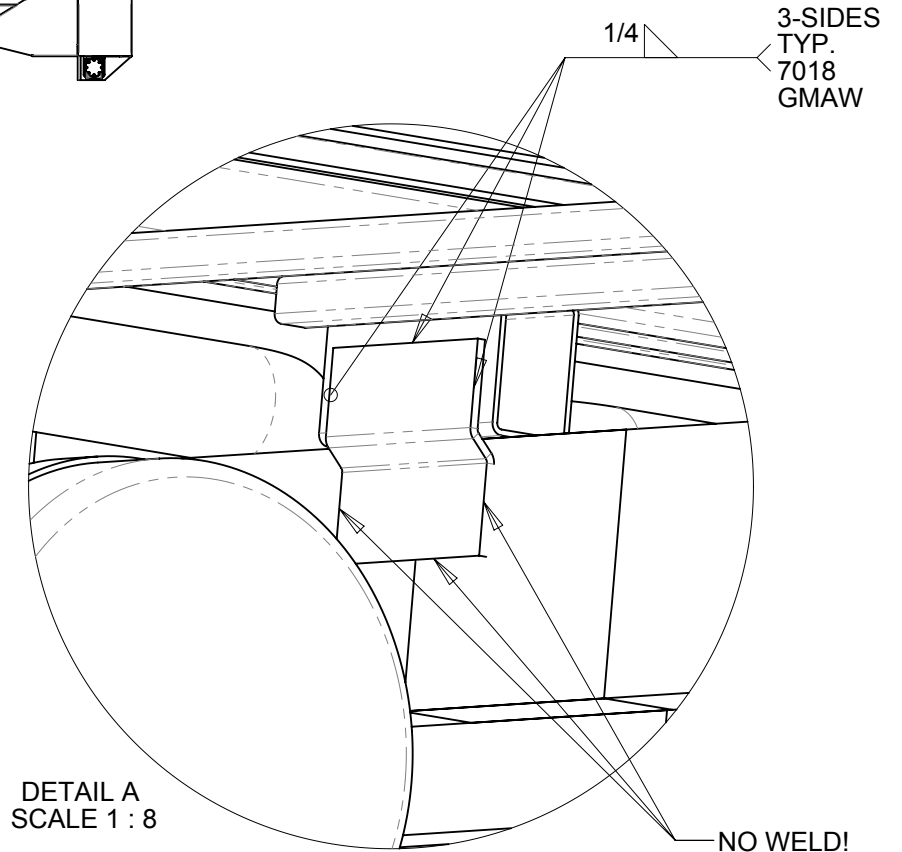
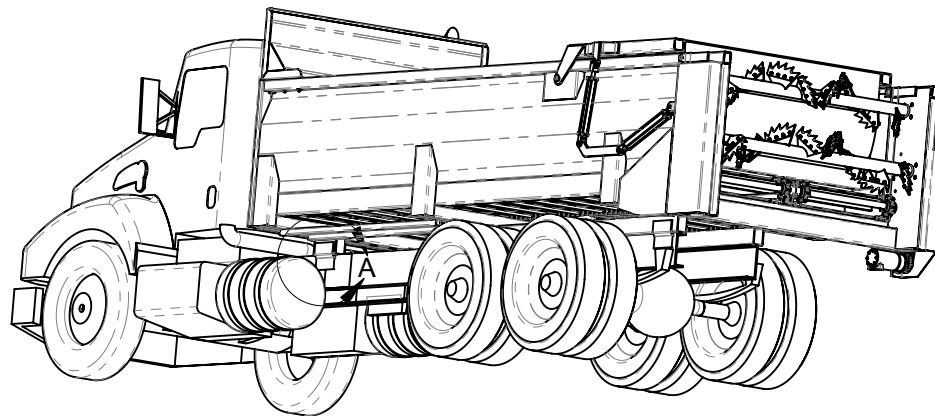

DETAIL A
SCALE 1 : 8

MOUNTING NOTES:

1. DO NOT WELD TO TRUCK FRAME
2. USE ALL (6) WELD TABS
3. MOUNT (2) POINTS FRONT
4. MOUNT (4) POINTS REAR
5. REAR MOUNTS CAN BE ARRANGED TO USE EXISTING HOLES
6. DRILL FRAME TABS 21/32" FOR 5/8 FASTENERS; (2) BOLTS PER FRAME TAB

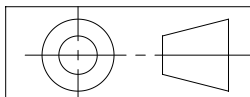

PROPRIETARY AND CONFIDENTIAL

THE INFORMATION CONTAINED IN THIS DRAWING IS THE SOLE PROPERTY OF FSI FABRICATION INC.. ANY REPRODUCTION IN PART OR AS A WHOLE WITHOUT THE WRITTEN PERMISSION OF FSI FABRICATION INC. IS PROHIBITED.

DIMENSIONS ARE IN INCHES
TOLERANCES:
FRACTIONAL $\pm 1/16$
ANGULAR: MACH ± 1 BEND ± 2
TWO PLACE DECIMAL $\pm .05$
THREE PLACE DECIMAL $\pm .005$

MATERIAL Material <not specified>

THICKNESS

DO NOT SCALE DRAWING

	NAME	DATE
DRAWN	SGC	
CHECKED		
ENG APPR.	SGC	



FSI FABRICATION

Mounting Layout 01

Frame Tabs

SIZE	DWG. NO.	REV.
A	Fp2 Mounting Layout	
SCALE:1:64	WEIGHT:	SHEET 1 OF 1